



# SEVEN SQUARE ACADEMY

Academic Year – 2020-2021

Secondary Section (Pre-board)

Name: \_\_\_\_\_

Subject: Science

Date: 03/03/2021

Class: X

Time: 3:00 Hours

Marks: 80 Marks

## General Instructions:

- (i) The question paper comprises four sections A, B, C and D. There are 36 questions in the question paper. All questions are compulsory.
- (ii) Section-A - question no. 1 to 20 - all questions and parts thereof are of one mark each.  
These questions contain multiple choice questions (MCQs), very short answer questions and assertion - reason type questions. Answers to these should be given in one word or one sentence.
- (iii) Section-B - question no. 21 to 26 are short answer type questions, carrying 2 marks each. Answers to these questions should be in the range of 30 to 50 words.
- (iv) Section-C - question no. 27 to 33 are short answer type questions, carrying 3 marks each. Answers to these questions should be in the range of 50 to 80 words.
- (v) Section-D - question no. - 34 to 36 are long answer type questions carrying 5 marks each. Answer to these questions should be in the range of 80 to 120 words.
- (vi) There is no overall choice. However, internal choices have been provided in some questions. A student has to attempt only one of the alternatives in such questions.
- (vii) Wherever necessary, neat and properly labeled diagrams should be drawn.

## SECTION A

1. Redraw the given diagram and show the path of the refracted ray (1)

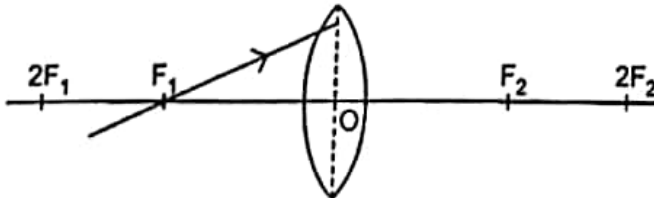

2. Both a spherical mirror and a thin spherical lens have a focal length of 20cm. What type of mirror and lens are these? (1)
3. It is desired to obtain an erect image of an object, using a concave mirror of focal length 12 cm. (1)
- (i) What should be the range of distance of the object from the mirror?
  - (ii) Will the image be bigger or smaller than the object?

Or

Why does a ray of light bend when it travels from one medium into another?

4. Two magnets are lying side by side as shown below. Draw magnetic field line between poles P and Q. (1)



5. Observe the figure given here and answer the following questions: (1)

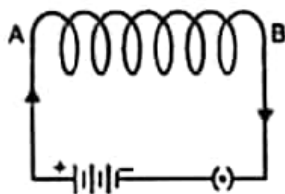

- (a) Write the special name given to the coil AB which has many circular turns of insulated copper wire.  
 (b) List two factors on which the strength of the magnetic field produced by AB depends.
6. Identify the circuit in which the electrical components have been properly connected. (1)

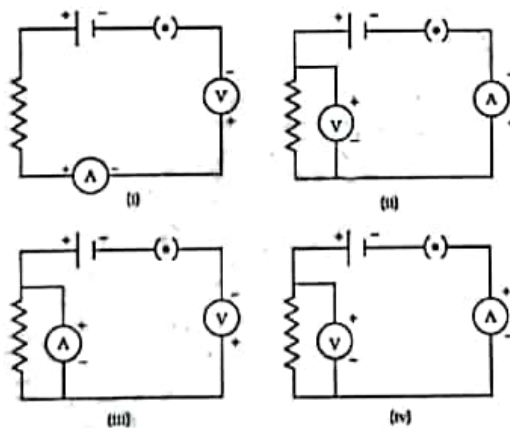

OR

Some work is done to move a charge  $Q$  from infinity to a point A in space. The potential of the point A is given as  $V$ . What is the work done to move this charge from infinity in terms of  $Q$  and  $V$ ?

7. Read the following and answer any four questions from 7 (i) to 7 (v) (4)

Rainbows are produced by a combination of refraction and reflection. You may have noticed that you see a rainbow only when you look away from the sun. Light enters a drop of water and is reflected from the back of the drop. The light is refracted both as it enters and as it leaves the drop. Since the index of refraction of water varies with wavelength, the light is dispersed, and a rainbow

is observed. (There is no dispersion caused by reflection at the back surface, since the law of reflection does not depend on wavelength.) The actual rainbow of colors seen by an observer depends on the myriad of rays being refracted and reflected toward the observer's eyes from numerous drops of water. The arc of a rainbow comes from the need to be looking at a specific angle relative to the direction of the sun.

We see about six colors in a rainbow—red, orange, yellow, green, blue, and violet; sometimes indigo is listed, too. These colors are associated with different wavelengths of light. White light, in particular, is a fairly uniform mixture of all visible wavelengths. Sunlight, considered to be white, actually appears to be a bit yellow because of its mixture of wavelengths, but it does contain all visible wavelengths. The sequence of colors in rainbows is the same sequence as the colors plotted versus wavelength. What this implies is that white light is spread out according to wavelength in a rainbow. Dispersion is defined as the spreading of white light into its full spectrum of wavelengths. More technically, dispersion occurs whenever there is a process that changes the direction of light in a manner that depends on wavelength. Dispersion, as a general phenomenon, can occur for any type of wave and always involves wavelength-dependent processes.

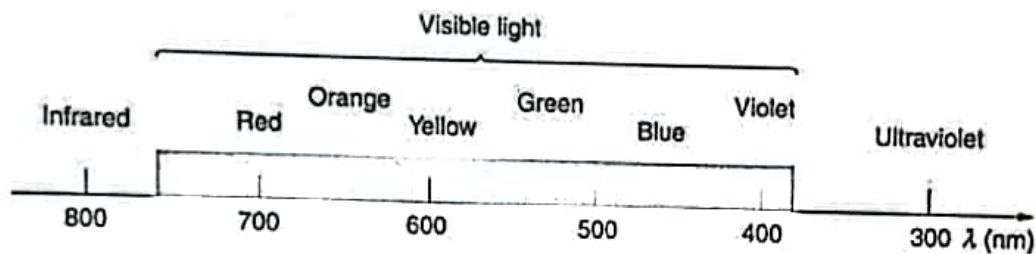

i) By which optical phenomenon does the splitting of white light into seven constituent colours occur?

- [A] Refraction
- [B] Reflection
- [C] Dispersion
- [D] Interference

ii) Which colours are reflected when white light is incident on blue pigment?

- [A] Yellow, Orange, Green
- [B] Violet, Green, Blue
- [C] Violet, Yellow, Green
- [D] Yellow, Green, Blue

iii) Sun appears ..... when it is near horizon

- [A] red
- [B] blue
- [C] white
- [D] pale blue

iv) Which colour of light deviates minimum in the dispersion of white light by prism?

- [A] Violet
- [B] Blue
- [C] Green
- [D] Red

v) Which phenomenon is responsible for the twinkling of stars?

- [A] Atmospheric reflection
- [B] Atmospheric refraction
- [C] Reflection
- [D] Total internal reflection

(4)

Read the following and answer any four questions from 8(i) to 8(v)

8.

An electric motor is a device that converts electrical energy to mechanical energy. It is of two types : AC and DC Motor.

Electrical energy is converted into mechanical energy by using an electric motor. Electric motor works on the basis of rule suggested by Marie Ampere and Fleming's Left Hand Rule. When a rectangular coil is placed in a magnetic field and a current is passed through it, force acts on the coil, which rotates it continuously. With the rotation of the coil, the shaft attached to it also rotates. When an electric current is supplied to the coil of the electric motor, it gets deflected because of magnetic field. As it reaches the halfway, the split ring which acts as commutator reverses the direction of flow of electric current. Reversal of direction of the current, reverses the direction of forces acting on the coil. The change in direction of force pushes the coil, and it moves another half turn. Thus, the coil completes one rotation around the axle. Continuation of this process keeps the motor in rotation.

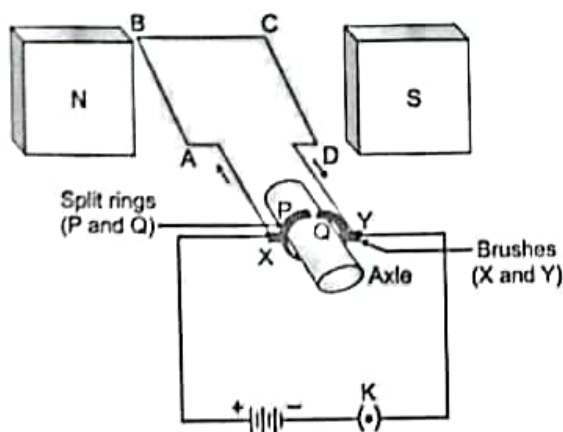

- i) An electric motor is a device which transforms
- (a) Mechanical energy into electrical energy
  - (b) Electrical energy into mechanical energy
  - (c) Kinetic energy into potential energy
  - (d) Electrical energy into Potential energy
- ii) Which of the following rule is used to determine the direction of rotation of D.C motor?
- a) Coulomb's Law
  - b) Lenz's Law
  - c) Fleming's Right-hand Rule
  - d) Fleming's Left-hand Rule
- iii) To make the coil keep rotating, the current is reversed after every half turn by a device called
- a) brush
  - b) commutator
  - c) mutator
  - d) carbon spring
- iv) The magnetic field of the coil and the permanent magnet
- a) attract each other
  - b) repel each other
  - c) combine with each other
  - d) stay with each other
- v) Carbon brushes are used in electric motors to
- a) Prevent sparking during commutation
  - b) Provide a path for flow of current
  - c) Brush off carbon deposits on the commutator
  - d) None of these

9. Consider the following equation of the chemical reaction of a metal 'M': (1)
- $$4M + 3O_2 \rightarrow 2M_2O_3$$
- This equation represents:
- (a) combination reaction as well as reduction reaction
  - (b) decomposition reaction as well as displacement reaction
  - (c) oxidation reaction as well as displacement reaction
  - (d) combination reaction as well as oxidation reaction

**OR**

- Exposure of silver chloride to sunlight for a long duration turns grey due to
- (i) the formation of silver by decomposition of silver chloride
  - (ii) sublimation of silver chloride

- (iii) decomposition of chlorine gas from silver chloride
- (iv) oxidation of silver chloride

- (a) (i) only
- (b) (i) and (ii)
- (c) (ii) and (iii)
- (d) (iv) only

10. Which of the statements about the reaction below are incorrect? (1)

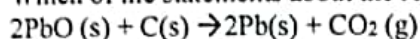

- (i) Lead is getting reduced
- (ii) Carbon-dioxide is getting oxidized
- (iii) Carbon is getting oxidized
- (iv) Lead oxide is getting reduced

- (a) (i) and (ii)
- (b) (i) and (iii)
- (c) (i), (ii) and (iii)
- (d) (i), (ii), (iii) and (iv)

11. Which of the following statements are correct for carbon compounds? (1)

- (i) Most carbon compounds are good conductors of electricity
- (ii) Most carbon compounds are poor conductors of electricity
- (iii) Force of attraction between molecules of carbon compounds is not very strong
- (iv) Force of attraction between molecules of carbon compounds is very strong

- (a) (ii) and (iv)
- (b) (ii) and (iii)
- (c) (i) and (iv)
- (d) (i) and (iii)

12. **Assertion:** Chemical bonds in carbon compounds are covalent in nature (1)

**Reason:** Covalent bond is formed by the sharing of electrons

- (a) Both Assertion and Reason are true, and Reason is the correct explanation of the Assertion.
- (b) Both Assertion and Reason are true, but Reason is not the correct explanation of the Assertion.
- (c) Assertion is true, but Reason is false.
- (d) Both Assertion and Reason are false.

13. **Read the following and answer all four (4) questions each carries one marks:** (4)

**Atomic size:** the term atomic size refers to the radius of an atom. The atomic size may be visualized as the distance between the center of nucleus and the outermost shell of an isolated atom. The atomic radius of hydrogen atom is 37 pm (picometer,  $1 \text{ pm} = 10^{-12} \text{ m}$ )

Variation of atomic radius with atomic number across the second period is given below

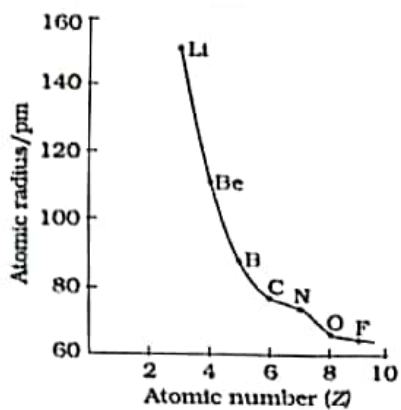

- a) Which of the following correctly represented the increasing order of atomic size
- (a) F, N, Be, Li
  - (b) Be, B, N, O
  - (c) Li, Be, O, F
  - (d) B, C, N, F
- b) 1 pm is
- (a)  $10^{-10}$  m
  - (b)  $10^{-12}$  m
  - (c)  $10^{-15}$  m
  - (d)  $10^{-9}$  m
- c) Atomic radius of H and Li are:
- (a) 150 pm and 150 pm
  - (b) 100 pm and 150 pm
  - (c) 37 pm and 150 pm
  - (d) 150 pm and 37 pm
- d) Across the second period when atomic number increases atomic size
- (a) increases
  - (b) remains same
  - (c) increases then decreases
  - (d) decreases

14. Arteries have thick and elastic walls. Justify

(1)

15. Name the substrates for the following enzymes: (1)
- trypsin
  - amylase
  - pepsin
  - lipase

OR

The inner lining of the small intestine has numerous finger-like projections. What are they termed as? What is its role?

16. Consider the food chain: (1)

Grass  $\longrightarrow$  Deer  $\longrightarrow$  Lion

What can be the consequence if lions are removed from the above food chain?

OR

State any two practices which can help in the protection of our environment

17. What is the role of saliva in the digestion of food? (1)

For question number 15 and 16, two statements are given- one labeled Assertion (A) and the other labeled Reason (R). Select the correct answer to these questions from the codes (a), (b), (c) and (d) as given below:

- Both A and R are true, and R is correct explanation of the assertion.
- Both A and R are true, but R is not the correct explanation of the assertion.
- A is true, but R is false.
- A is false, but R is true.

18. (1)
- Assertion (A):** Flow of energy in a food chain is unidirectional  
**Reason (R):** Energy captured by the autotrophs does not revert back to the solar input and it passes to the herbivores

OR

**Assertion (A):** Polythene bags and plastic containers are non-biodegradable substances  
**Reason (R):** They can be broken down by microorganisms into natural simple harmless substances

19. (1)
- Assertion (A):** When heterozygous tall plants were self crossed, the result obtained were both tall and short plant.  
**Reason (R):** Heterozygous plants contain both dominant and recessive alleles.



20. Read the following and answer any four questions from 17 (i) to 17 (v)

(4)

The food material taken in during the process of nutrition is used in cells to provide energy for various life processes. Diverse organisms do this in different ways – some use oxygen to break-down glucose completely into carbon dioxide and water, some use other pathways that do not involve oxygen.

(i) The breakdown of pyruvate to give carbon dioxide, water and energy takes place in:

- a. Cytoplasm
- b. Mitochondria
- c. Chloroplast
- d. Nucleus

(ii) A graph was plotted to show the energy output of two types of respiration. Identify the types of respiration denoted by curves A and B.

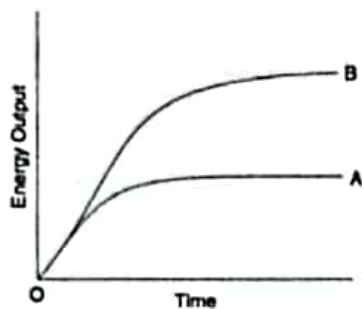

(iii) The correct sequence of anaerobic reactions in yeast is:

- a. Glucose  $\xrightarrow{\text{cytoplasm}}$  Pyruvate  $\xrightarrow{\text{mitochondria}}$  Ethanol + Carbon dioxide
- b. Glucose  $\xrightarrow{\text{cytoplasm}}$  Pyruvate  $\xrightarrow{\text{cytoplasm}}$  Lactic acid
- c. Glucose  $\xrightarrow{\text{cytoplasm}}$  Pyruvate  $\xrightarrow{\text{mitochondria}}$  Lactic acid
- d. Glucose  $\xrightarrow{\text{cytoplasm}}$  Pyruvate  $\xrightarrow{\text{cytoplasm}}$  Ethanol + Carbon dioxide

(iv) Why is some KOH placed in a small test tube in the flask with germinating seeds in the experiment to demonstrate the occurrence of respiration in germinating seeds?

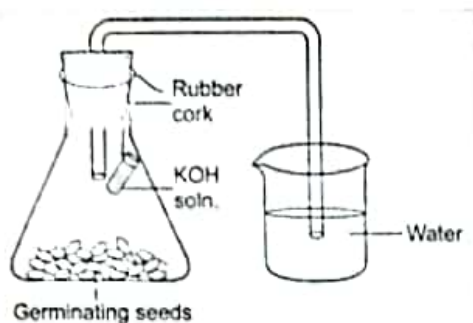

- To provide oxygen required by the seeds for respiration
- To absorb carbon dioxide and create partial vacuum in the flask
- To absorb water from the seeds to make them dry
- To make the air present in the flask alkaline

(v) Which of the following statements is/are correct?

- Energy produced during respiration is stored in the form of ATP in animals
- ADP has high energy content as compared to ATP
- Respiration is just same as photosynthesis
- All of the above

### SECTION B

- What is meant by scattering of light? Why does the clear sky appear blue? (2)
- State Joule's law of heating?
  - An electric iron has a rating of 750W:220V. Calculate
    - current consumed by it
    - its resistance when in use.

- Explain the term 'Catenation' property shown by carbon compound
  - Draw the electron dot structure of Methane molecule (depict all the valence electrons)

**OR**

- Explain the term 'Homologous series' of carbon compound with an example
  - Draw the electron dot structure of Ethane molecule (depict all the valence electrons)
- Show the electron dot structure of the formation of Magnesium fluoride from Magnesium and fluoride ions (depict the movement of electrons clearly)
    - Why do ionic compounds conduct electricity in molten state whereas, not conduct electricity in the fused state?
  - Why are molecular movements needed for life? (2)

**OR**

Define the term blood pressure. Name the instrument used for measuring blood pressure.

26. a. Two green plants are kept separately in oxygen free containers, one in dark and the other in continuous light. Which one will live longer? Give reasons. (2)
- b. How do the guard cells regulate the opening and closing of stomatal pores?

### SECTION C

27. i) Define resistance. what are the factors affecting resistance. (3)
- ii) The figure below shows three cylindrical copper conductors along with their face areas and lengths. Discuss in which geometrical shape the resistance will be highest.

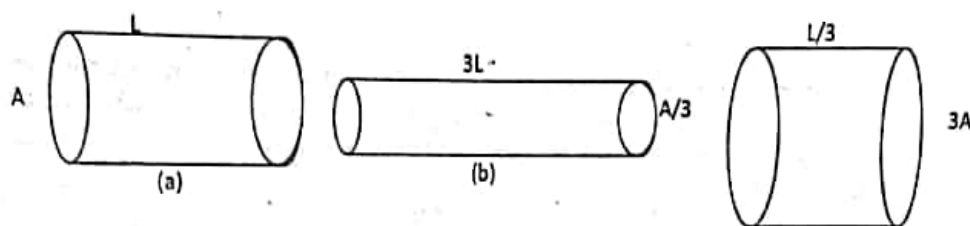

28. (a) Define a combination reaction with a suitable example (3)
- (b) What is the colour of ferrous sulphate crystals? How does the colour change after heating?
- (c) Write the balanced chemical equation: Barium chloride solution reacts with sodium sulphate solution to give insoluble barium sulphate and a solution of sodium chloride.
29. (a) Arrange the following metals in an increasing order of their reactivity towards water: (3)  
**Zinc, Iron, Magnesium, Sodium**
- (b) Name one metal more reactive and another less reactive than hydrogen
- (c) Name one metal which displaces silver from silver nitrate solution and one which do not.
30. (a) Name one element that have a single electron in their outermost shells (3)
- (b) Name one element that have complete octet
- (c) Which element having electronic configuration 2,8,3
31. "Different species use very different strategies for this. Some rely entirely on environmental cues whereas in some its genetically determined". Explain the statement by giving example for each strategy. (3)

**OR**

Explain Mendel's experiment with peas on inheritance of characters considering only one visible contrasting character.

32. Define trophic level. What is the difference in the food habits of organisms belonging to the first and the third trophic level? Give one example of each of the organisms belonging to these two trophic levels. (3)

33. a. Name the basic filtration unit present in the kidney. (3)  
 b. Name the substances that are reabsorbed from the initial filtrate in the tubular part of this filtration unit  
 c. Under what conditions are hemodialysis (artificial kidney) carried out in a person?

**SECTION D**

34. (a) If the image formed by a lens is diminished in size and erect, for all positions of the object, what type of lens is it? (5)  
 (b) Name the point on the lens through which a ray of light passes undeviated.  
 (c) An object is placed perpendicular to the principal axis of a convex lens of focal length 20 cm. The distance of the object from the lens is 30 cm. Find (i) the position (ii) the magnification and (iii) the nature of the image formed

OR

- a) State Flemings left hand rule  
 b) State principle of electric motor.  
 c) With the help of following diagram of experimental setup describe an activity to show that the force acting on a current carrying conductor placed in a magnetic field increases with increase in field strength.

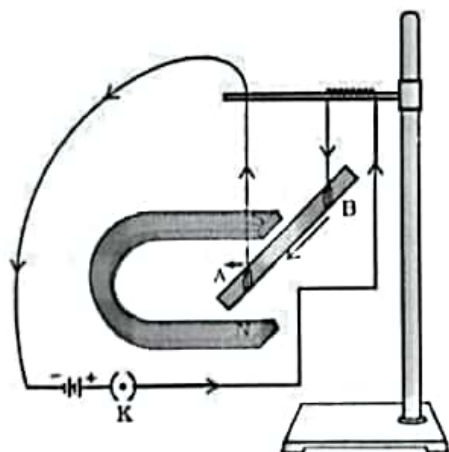

35. (a) How is bleaching powder prepared? (5)  
 (b) Write the chemical formula of plaster of Paris  
 (c) Write the chemical formula of baking soda  
 (d) Give two important uses of washing soda  
 (e) Explain why plaster of Paris stored in a moisture-proof container

OR

- (a) Define an acid and a base. Give one example each  
 (b) Give the names and formula of one weak acid and one weak base  
 (c) What type of ion is formed when:  
 (i) an acid is dissolved in water? (ii) a base is dissolved in water  
 (d) Write the neutralization reaction between acids and bases (balance the equation)  
 (e) Differentiate between weak acid and dilute acids

36. a. Draw a diagram of the longitudinal section of a flower exhibiting germination of pollen on stigma and label ovary, male germ cell, pollen tube and female germ cell on it. (3)
- b. Explain the different types of pollination. List two agents of pollination. (2)

**-END-**